

**NOTES:**

1. To be tightened according to Aprilia Tuareg 660 Workshop Manual.
2. Do not use Loctite or other thread locking compounds. Use copper grease.

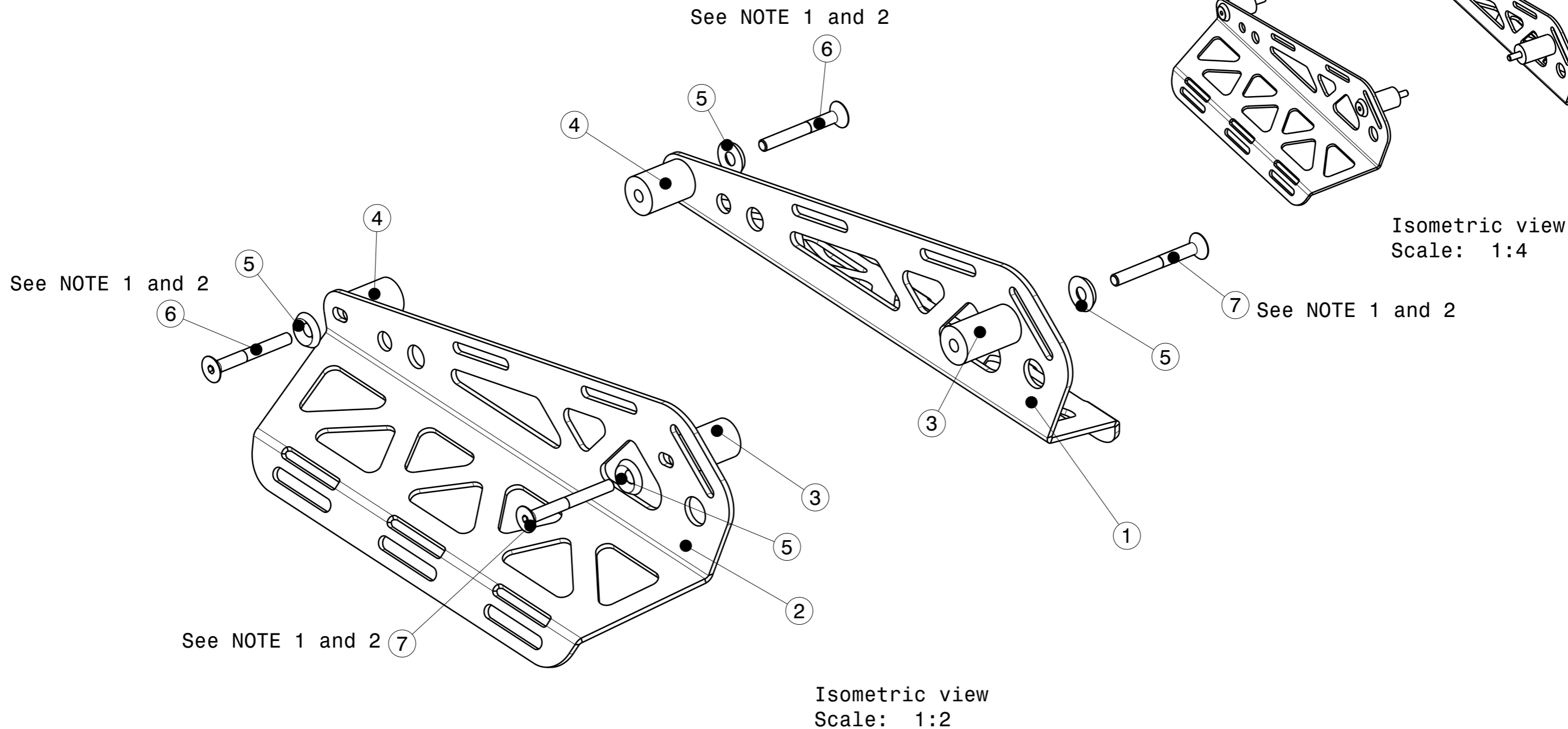

PART LIST			
Description	Part Number	F/N	Qty
Side Rack L	FGWX-05-A-001	1	1
Side Rack R	FGWX-05-A-002	2	1
Spacer 6x20x30		3	2
Spacer 6x20x35		4	2
Csk Washer M6		5	4
Csk Screw M6x55		6	2
Csk Screw M6x50		7	2

SCALE 1:1		BREAK ALL EDGES (R ALT. 45°) 0.1-0.5 THREAD TOL. 6g/6H ISO R965/1 ALL DIM. INCLUDE SURFACE TREATMENT		<b>GWORX</b>	
ROUGH Ra μm	FILLET RADII	DIM TOL	ANG TOL	PROJECTION	
DATE		DESCRIPTION Side Racks			
DESIGN GWORX		-			
DRAWN GWORX		-			
MAT.		SURF. TREATMENT			
SIZE	DOC. NO. FGWX-05-A	REV.	SHEET 1 OF 1		